

A (1:5)

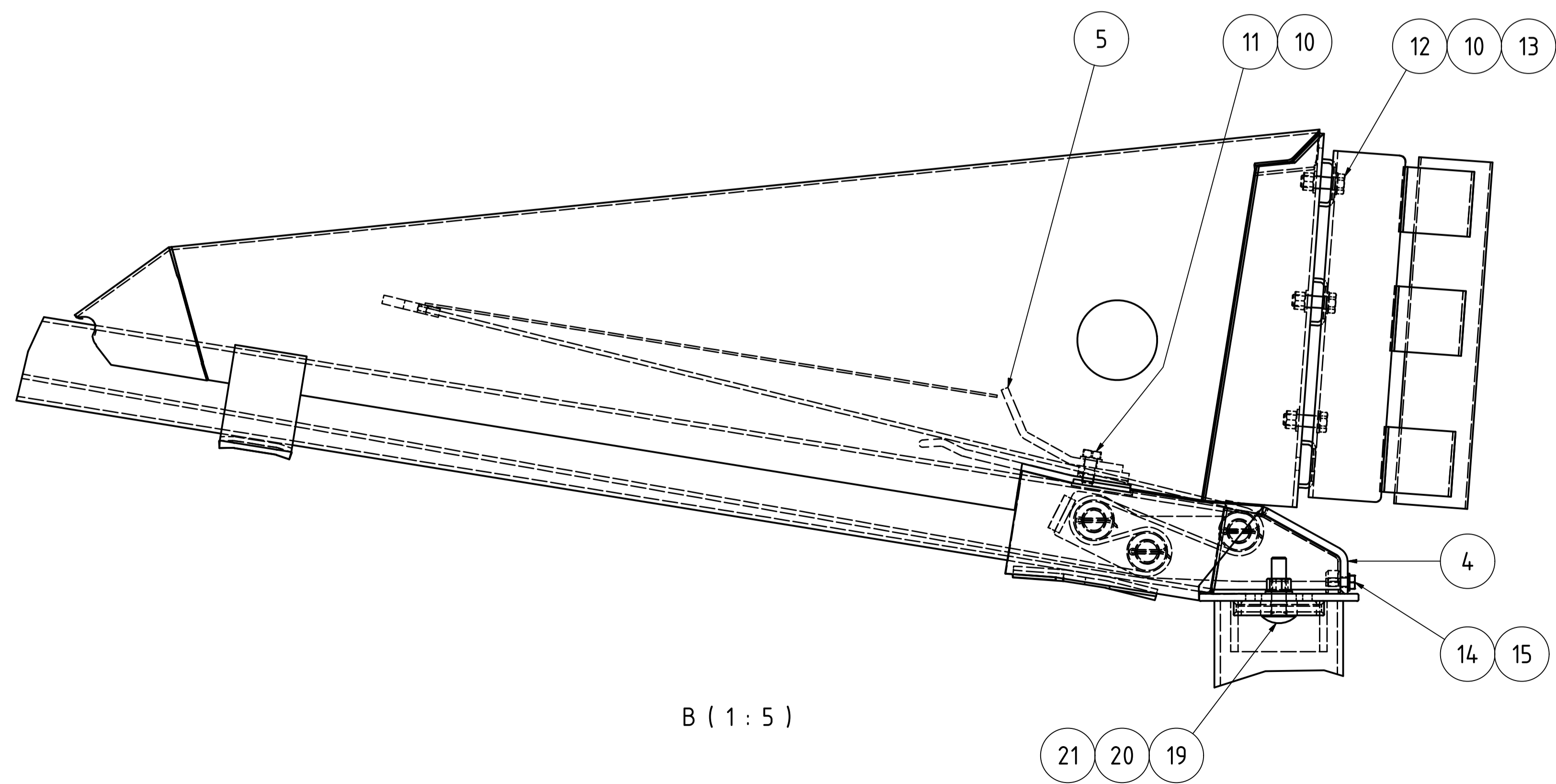

B (1:5)

Item No	Qty.	Description	Material	Dimension	Note
21	2	HEX NUT M6M M20	8.	M20	
20	2	WASHER	HV 200	21 x 36	
19	2	MUSHROM HEAD SCREW	8.8	M20 x 80	
18	1	"NAIL"	S 355		8920531-CRT
17	1	C-POST	S 355		8920301-CRT
16	1	CONNECTOR PLATE M12	S 355		8920505-CRT
15	2	WASHER	HV 200	13 x 24	
14	2	SCREW	8.8	M12 x 30	
13	6	HEX NUT M6M M16	8.	M16	HDG
12	6	SCREW	8.8	M16 x 50	HDG
11	2	SCREW	8.8	M16 x 35	HDG
10	16	WASHER	HV 200	17 x 30	HDG
9	2	SCREW	8.8	M16 x 80	HDG
8	1	THREADED PLATE M16			8920092-CRT
7	1	DISTANCE POST			8920090-CRT
6	1	C PROFILE 85x35x22,5x4			8920504-CRT
5	1	BRAKE BAND, BRAKET			8920015-CRT
4	1	BRAKE ASSEMBLY			89210501-CRT
3	1	DEFORMATION ELEMENT			8920061-CRT
2	1	BOX			8920062-CRT
1	1	SafeEnd TUBE			8921102-CRT

ASSEMBLY DRAWING						In Review				
Design	Drawn	Copied	Checked	Stand.	Appr.	Scale	Replaces	Replaced by	Date	Rev.
GLN	GLN		FSO		FSO				2015-06-16	
SAFEROAD SafeEnd P2								Drawing no. 8921080-CRT		